

Document No	P13-ÜT81
Revision Date	15.11.2012
Revision No	00
Revision Date	00
Page No	1/1

OHC 500 (V64) 500 CC OVAL HINGED CONTAINER

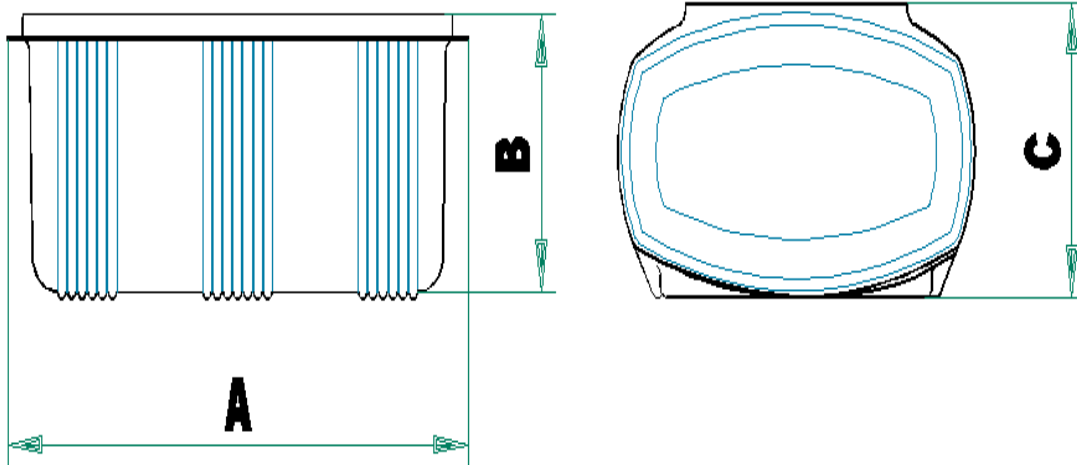

WEIGHT

Dimensions	A (mm)	B (mm)	C (mm)
	115	54	145

MIN	MAX
<b>14,73</b>	<b>15,50</b>

PRODUCT INFORMATION

Piece /Kg / Time	Product Weight $\pm\%2,5$ (g)	Gross Box Weight $\pm\%2,5$ (Kg)	Quantity per Boc (Pcs)	Minutes for 1000 pcs	Pcs / 1000 kg	Sheet (kg) for 1000 pcs
	15,1	8,7575	500	3,57	49394,91	20,245

Production Details	Box per Hour (pcs)	Product per Hour (pcs)	Ullage Factor	Tool Cavity (pcs)	Production Rate (cycle / minute)	Sheet Dimensions
	33,60	16800	5,13	8	35	0,32 x 765

Knife, Box and Sleeve Bag	Knife Ref	Length of Knife (m)	Box Ref	Inner Box Dimensions L x W x H (mm)	Sleeve Bag Dimensions (mm)
	L11011928	6,7	102	580 x 397 x 505	40 x 80